

ESAB DC ArcPower LCF 1000 Gouging Machine

LCF 1000 is a powerful thyristor controlled rectifier designed for Stick (mma) Welding and for Arc Air Gouging with carbon electrodes.

Based on well proven technology to handle heavy workloads and demanding working environments.

Designed and manufactured to the latest International standards.

IP23 protection class allows for both indoor and outdoor use.

The rectifier is forced fan cooled, is equipped with multiple thermostats to protect against overloading and an overcurrent protection system.

High duty cycle heavy duty performance.



Technical data

Product name	LCF 1000			
Mains supply, V	3x400	3x440	*3x500	*3x550
Frequency, Hz	50	60	50	60
Connection cable, mm ²	4x35	4x35	4x25	4x25
Permitted load:				
Duty cycle, %	100	60		
Current, A	1000	1200		
Voltage, V	44	44		
Welding current range, A	70-1250			
Open circuit voltage, V	75			
Power factor cos Ø	0.84(1200A)			
Insulation class	H			
Protection	IP23			
Dimensions (LxWxH), mm	765x555x1020			
Standard	EN 60 974-1			
Weight, kg	380			

*option

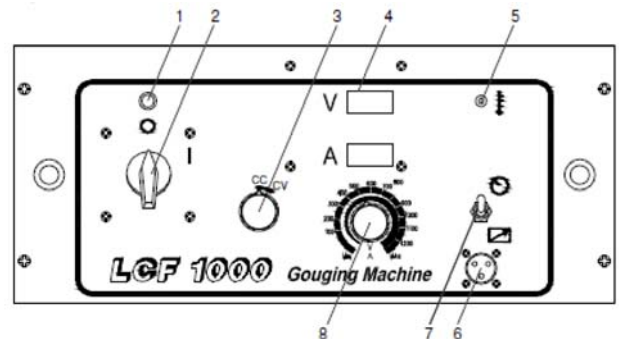

- Green lamp, power supply ON
- Mains supply switch
- Method selector switch CC/CV
- Voltmeter & Ammeter (option)
- Yellow lamp, thermal cut-out
- Remote control socket
- Remote control switch
- Current / Voltage setting switch

Ordering information

LCF 1000 powersource 0159 850 880

Optional

Digital volt and amp meters 0159 850 004
 Remote control switch 0700 101 006
 Remote control 3 pole connector 0700 161 007
 K4000 gouging torch with cable (2m) 0760 018 100

ESAB Asia/Pacific Pte Ltd

38 Joo Koon Circle
 Singapore 629063
 Tel: +65 6861 4322
 Fax: +65 6861 3195
 Email: machines@esabasia.com
 Website: www.esabasia.com